



# Agilent AN 1288-4

## How to Characterize CATV Amplifiers Effectively

Application Note

Using the Agilent 4396B  
RF Network/Spectrum/  
Impedance Analyzer

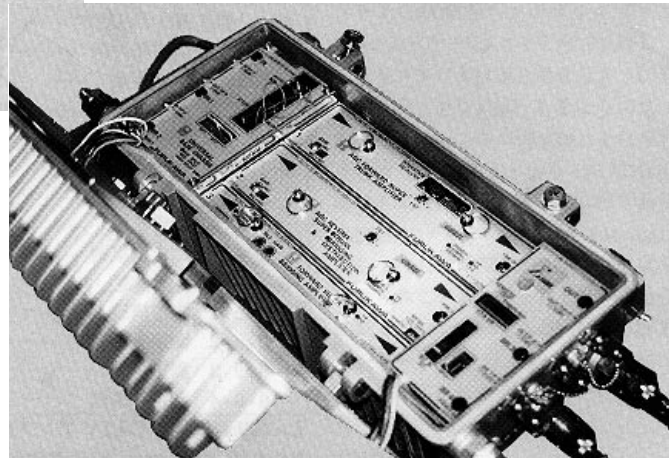
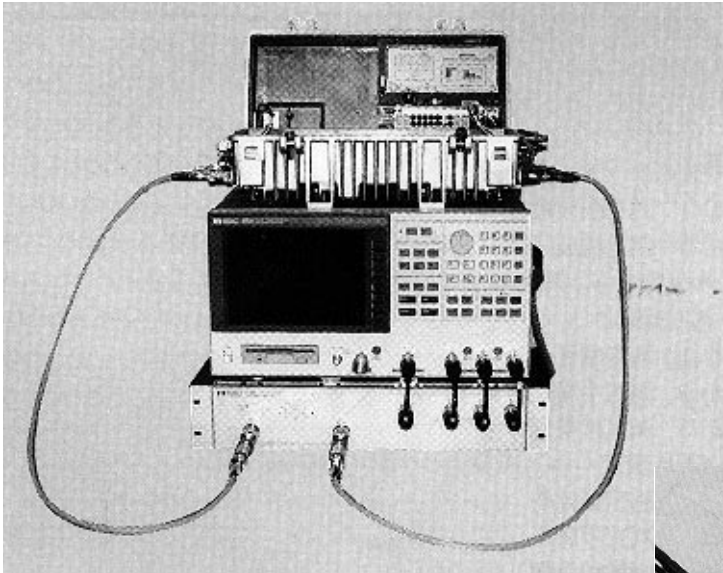

**Agilent Technologies**

Innovating the HP Way

# Page Contents

<b>3</b>	<b>Introduction</b>
<b>3</b>	<b>1. CATV System Configuration</b>
<b>5</b>	<b>2. Main Features of a CATV Amplifier</b>
<b>5</b>	<b>3. Evaluation Parameters for a CATV Amplifier</b>
<b>6</b>	<b>4. CATV Amplifier Measurement Using the Agilent 4396B RF Network/Spectrum/Impedance Analyzer</b>
6	4-1. Requirements for Network/Spectrum Analyzer
6	4-2. Agilent 4396B Basic Performance
7	4-3. Features of the Agilent 4396B
<b>8</b>	<b>5. Network Measurement of CATV Amplifier Using the Agilent 4396B</b>
8	5-1. Network Measurement Setup
9	5-2. Transmission Characteristic (Amplitude-Phase) Measurement
9	5-3. Gain Control Capability Evaluation for Cable Loss Compensation
9	5-3-1. <i>Cable loss compensation</i>
11	5-3-2. <i>Efficient evaluation of gain control capability</i>
15	5-3-3. <i>Example of evaluation</i>
16	5-4. Reflection Coefficient (SWR-Return Loss) Measurement
<b>18</b>	<b>6. CATV Amplifier Spectrum Measurement</b>
18	6-1. Spectrum Measurement Parameters and Definitions
20	6-2. Agilent 4396B Features in CATV Amplifier Spectrum Measurement
20	6-3. Spectrum Measurement Setup
20	6-3-1. <i>Reference level calibration</i>
21	6-3-2. <i>Measurement system configuration</i>
22	6-4. Multi-channel Signal Measurement
22	6-5. Composite Triple Beat (CTB)
22	6-5-1. <i>Example of measurement conditions</i>
23	6-5-2. <i>Measurement procedure</i>
23	6-5-3. <i>Example of measurement results</i>
24	6-6. Composite Second Order Beat (CSO)
24	6-6-1. <i>Example of measurement conditions</i>
25	6-6-2. <i>Measurement procedure</i>
25	6-6-3. <i>Example of measurement results</i>
25	6-7. Cross Modulation Distortion
25	6-7- 1. <i>Example of measurement conditions</i>
25	6-7- 2. <i>Measurement procedure</i>
26	6-7- 3. <i>Example of measurement results</i>
28	6-8. Inter-modulation Distortion (IMD)
28	6-8-1. <i>Measurement system configuration</i>
28	6-8-2. <i>Example of measurement conditions</i>
29	6-8-3. <i>Measurement procedure</i>
29	6-8-4. <i>Example of measurement results</i>
30	6-9. Hum Modulation
30	6-9-1. <i>Measurement system configuration</i>
31	6-9-2. <i>Example of measurement conditions</i>
31	6-9-3. <i>Measurement procedure</i>
31	6-9-4. <i>Example of measurement results</i>
<b>32</b>	<b>7. Agilent 4396B Features for CATV Amplifier Measurement</b>
<b>33</b>	<b>Conclusion</b>

## Introduction

CATV technology has matured steadily over the past several decades, and has expanded into increasingly diverse applications. Although the business started for the purpose of serving remote areas that were not accessible by ordinary TV broadcasting, its extra-wide bandwidth permits the delivery of dozens of channels of entertainment and business video to a variety of viewers, far removed from those simple community-oriented applications of the early years.

With the recent expansion in technology and service, it has become increasingly important to improve CATV system component performance in order to provide transmitted visual and audio signals of higher quality to each subscriber. This leads to more rigorous requirements on CATV equipment performance. Typically, the CATV amplifier is the key element of such equipment that requires upgraded performance for the major role it plays in amplifying damped TV signals (compensating for loss of signal power).

Amplifier performance can be evaluated based on measurements of a variety of parameters, most of which are checked through network and spectrum analysis. This application note shows you how to effectively evaluate CATV amplifier performance using the Agilent Technologies 4396B Network/Spectrum/Impedance Analyzer.

# 1. CATV System Configuration

First, a brief overview of the typical CATV system configuration is shown in Figure 1. Using Figure 1, the basic system components will be described.

## Head end

This system component receives TV signals off the air or from satellite feeds, and supplies them to the transmission system. In this application note, “transmission system” means all lines extending from the head end to the subscriber’s terminal.

## Trunk line

This line is a signal transmission line extending from the head end to the center of each zone within the service area. This line is the longest of all lines in the transmission system and plays the most important part of all lines by sending master signals to other transmission lines. Typically low-loss coaxial cable is used for this line. The component used to compensate for signal damping within this line is called a trunk amplifier (TA). Among all CATV amplifiers, this amplifier must meet the most rigorous requirement for low distortion and noise.

In addition to the TA, there are two other trunk amplifiers; trunk distribution amplifiers (TDA), and trunk branch amplifiers (TBA), that are used to divide a single input line into multiple output lines.

## Branch line (BL)

This is a transmission line branching from the trunk line via TDA. The branch amplifier (BA) is used to compensate for signal damping within this line.

### Feeder line (FL)

This is a transmission line branching from the trunk line via trunk branch amplifier (TBA) or from a branch line via branch amplifier (BA). Extension amplifier (EA) is used to compensate for signal damping caused by cable and tapoff effects.

### Drop line (DL)

This is a transmission line branching from a feeder line via tapoff. Video signals are received by each subscriber through this line.

An operating CATV system can transmit TV signals from the head end to subscribers (forward or downward transmission) and also transmit the system status monitored at the head end and images recorded in the service area back to the studio (upward transmission). Channel frequency assignments vary between 70 MHz and 452 MHz for downward transmission with a unique frequency allocated to each channel at 6 MHz intervals, and between 10 MHz and 50 MHz for upward transmission at 5 MHz intervals. Also, the input/output impedance of the system equipment is set at  $75\Omega$ , equal to that for the TV set, to ensure impedance-matched transmission of TV signals.

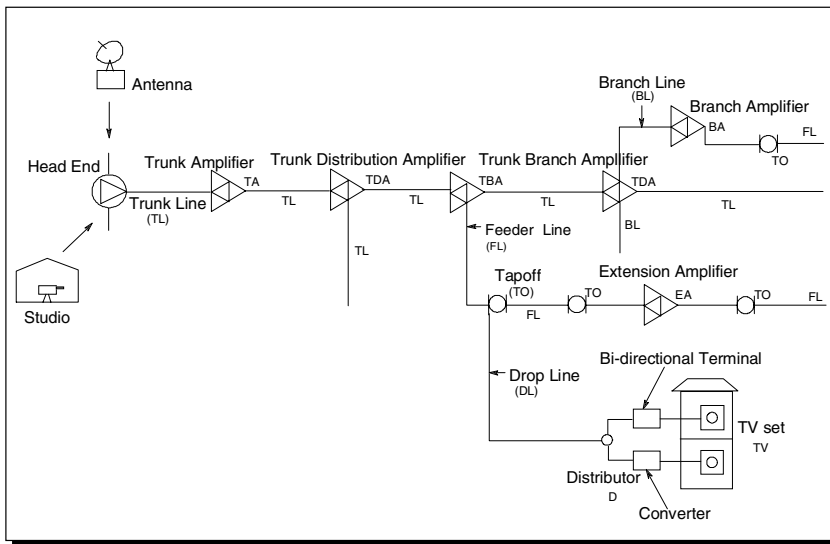

**Figure 1. CATV System Configuration**

- Antenna
- Head End
- TV Studio
- Trunk Line
- Trunk Amplifier
- Trunk Distribution Amplifier
- Feeder Line
- Tapoff
- Drop Line
- Branch Line
- Branch Amplifier
- Extension Amplifier
- Bi-directional Terminal
- Distributor
- Converter
- TV set

## 2. Main Features of a CATV Amplifier

The CATV amplifier is mainly used to amplify damped TV signals (compensation for loss) for improved signal quality before sending them to each subscriber.

In addition to this, the CATV amplifier provides the following functions:

- Amplifies signals over a wide bandwidth for multiple channel signal transmission
- Achieves minimum distortion and frequency characteristic fluctuation
- 75Ω input/output impedance
- Bi-directional device
- Variable gain to respond to change in ambient conditions

## 3. Evaluation Parameters for a CATV Amplifier

Electrical evaluation of a CATV amplifier, the most important part of evaluation, is conducted through network and spectrum measurements. The following lists the major measurement parameters:

### Network Measurement

- Amplitude (gain)
- Phase or group delay
- Standing wave ratio (SWR) and return loss
- (Agilent prefers the term SWR instead of the less-used term Voltage Standing Wave Ratio, VSWR)

### Spectrum Measurement

- Composite triple beat (CTB)
- Composite second order beat (CSO)
- Cross modulation distortion
- Inter-modulation distortion (IMD)
- Hum modulation

The following shows you how to accurately and efficiently measure the above parameters using the Agilent 4396B RF Network/Spectrum/Impedance Analyzer.

## 4. CATV Amplifier Measurement Using the Agilent 4396B RF Network/Spectrum/Impedance

### 4-1. Requirements for network/spectrum analyzer

A CATV amplifier must assure high qualities in signal transmission. To measure parameters of such a high-performance device, the instrument used for network and spectrum measurements must meet the following requirements:

#### Network Measurement

- Accurate amplitude and phase measurement
- Fast sweep for real time gain control evaluation

#### Spectrum Measurement

- Low noise level for small distortion measurement
- Fast measurement with narrow resolution bandwidth

The 4396B provides both network and spectrum measurements and meets the above requirements, without compromise. It is the best choice for CATV amplifier measurement.

### 4-2. Agilent 4396B Basic Performance

#### Network Measurement

*Frequency range:* 100 kHz to 1.8 GHz

*Dynamic measurement accuracy:*  $\pm 0.05$  dB

*Phase measurement accuracy:*  $\pm 0.3$  degree

*Dynamic range:* 120 dB or more (at IFBW=10 Hz) (IF bandwidth)

*Measurement speed:* 350  $\mu$ sec/point (at IFBW=40 Hz)

#### Spectrum Measurement

*Frequency range:* 2 Hz to 1.8 GHz

*Single-side band phase noise:* -105 dBc/Hz (-113 dBc/Hz typical), at 10 kHz offset

*Noise level:* -147 dBm/Hz (at 1 GHz)

*Measurement speed:* 1.3 sec (when RBW=100 Hz, span= 100 kHz) (resolution bandwidth)

### **4-3. Features of the Agilent 4396B**

#### **Combination Analyzer**

As the name implies, the 4396B RF Network/Spectrum/Impedance Analyzer allows both network and spectrum measurements. For further cost reduction, you can also configure the analyzer with an available impedance option to perform impedance analysis in the same instrument.

#### **Superior Performance Comparable to Dedicated Analyzer**

The 4396B offers performance comparable to, or even higher than, dedicated network analyzers and spectrum analyzers in terms of measurement speed, accuracy, dynamic range, and more.

#### **Highly Accurate Measurement**

With amplitude and phase measurement accuracy of  $\pm 0.05$  dB and  $\pm 0.3$  degrees, respectively, for network measurement, the 4396B ensures highly accurate measurement. Further, it offers total level absolute accuracy of  $\pm 0.1$  dB for spectrum measurement.

#### **High Speed Measurement**

With its network measurement speed of 350 msec (at IFBW=40 kHz) per point, the 4396B allows real time evaluation of amplifier gain control capability. Also, even when the resolution bandwidth is as narrow as 100 Hz with a sweep span of 100 kHz in spectrum measurement, the 4396B's stepped FFT (Fast-Fourier Transform) technique needs only 1.3 seconds for sweep time, about twenty times faster than conventional analyzers.

#### **Impedance-matched Measurement**

The 4396B ensures minimum loss during measurement of CATV amplifier with  $75\Omega$  input/output impedance.

#### **Powerful Marker-aided Analysis Functions**

You can use a variety of marker-aided analysis functions such as peak search and marker list to easily obtain the exact value from measurement curves.

#### **Other Useful Functions**

The limit line function used for Pass/Fail judgments allows quick testing of CATV amplifier gain control capability against established performance limits.

The list sweep function allows multiple sweep ranges to be measured by a single sweep for improved efficiency.

#### **IBASIC (Instrument BASIC) Function (available as standard with the 4396B )**

The IBASIC function allows the 4396B to operate as an instrument controller. Thus, the 4396B not only performs automatic measurement, but can also control external equipment to reduce cost and downsize the system.

### **Two Data Storage Functions**

The 4396B comes with two data storage media; 3.5" floppy drive supporting both LIF and DOS formats, and 512-kbyte RAM drive for high-speed access. Therefore, you can use the RAM disk to temporarily store IBASIC programs and measurement parameters while using a floppy disk, not just for storing parameters, but for processing measurement data and program files on an external PC.

## **5. Network Measurement of CATV Amplifier Using the Agilent 4396B**

Network measurement plays an important role in determining the CATV amplifier performance because signal loss compensation capability is a critical factor for the device. Phase measurement is as important for image quality as is amplitude measurement (amplifier transmission characteristic) for proper loss compensation.

For example, if the trunk amplifier phase characteristic is not linear vs frequency, phase shift caused by this amplifier will be conveyed sequentially to other amplifiers connected to it, thereby transmitting degraded images to subscribers. In addition to transmission characteristic, reflection characteristic should be carefully considered. If the amplifier is connected under mismatched impedance conditions to the CATV system composed of  $75\Omega$  impedance equipment, signal power reflection occurs, thereby affecting proper transmission of TV signals. In addition, re-reflections in random phase can also degrade signals by affecting the resultant video phase characteristics.

The next section of this note shows you how to make measurements for evaluation of the above characteristics.

### **5-1. Network Measurement Setup**

If an amplifier has two or more input or output terminals, as with a trunk branch amplifier, all terminals other than the one under test are terminated with  $75\Omega$  resistors to prevent signal power reflection. All CATV channel frequencies from 10 MHz to 452 MHz are applied to the unit under test for measurement. The recommended measurement system would, ideally, be composed of the 4396B and 85046B  $75\Omega$  S-parameter Test Set or 87512B  $75\Omega$  Transmission/Reflection Test Set. (You need to manually change cabling when you use the 87512B for bi-directional measurement.) Figure 2 shows a test system configuration using the 4396B and 85046B.

Calibration of your measurement system is vital to ensure accuracy in measurement. By manually changing cables, perform the following necessary measurements: full two-port calibration for bi-directional transmission/reflection characteristic measurement, and one-path two-port calibration for unidirectional measurement or bi-directional measurement.



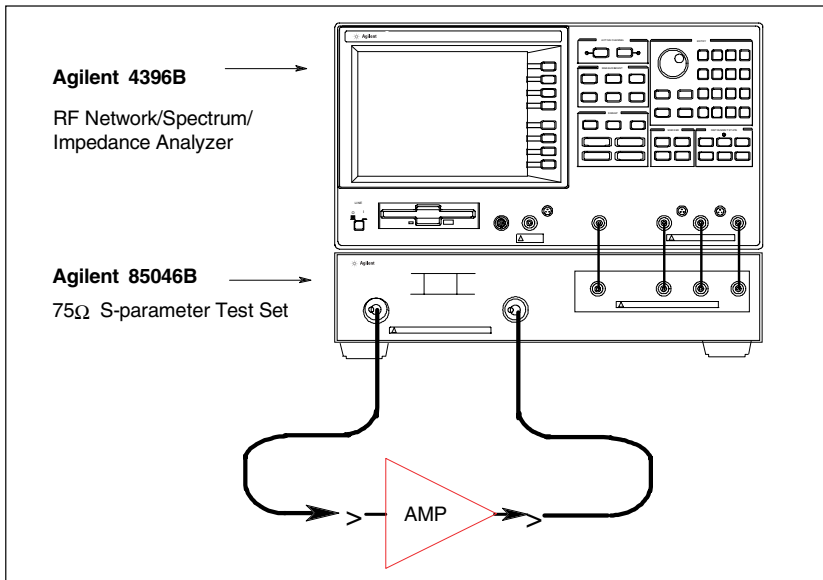

**Figure 2. Example of Network Measurement System Configuration**

- Agilent 4396B RF Network/Spectrum/Impedance Analyzer
- Agilent 85046B 75Ω S-parameter Test Set

## 5-2. Transmission Characteristic (Amplitude-Phase) Measurement

The above measurement system allows bi-directional measurement of amplitude as a function of phase (transmission characteristic) over the entire channel frequency band.

Figure 3 shows an example of downward transmission curves for amplitude-expanded phase. (Expanded phase format allows phase characteristic varying over 360 degrees to be displayed continuously on a single plane, without wrapping around every 360 degrees.)

## 5-3. Gain Control Capability Evaluation for Cable Loss Compensation

### 5-3-1. Cable loss compensation

The basic frequency characteristic formula for cable loss is shown in Equation 1.

#### Equation 1.

$$\text{Loss}(f) = a \cdot f + b \cdot \sqrt{f} + c$$

where,

Loss (f): Cable loss per unit length [dB/km]

f: Frequency [MHz]

a, b, c: Constants

This equation shows that cable loss per unit length increases with increase in frequency. (See Figure 4.) The actual cable loss varies depending not only on frequency and cable length but also on temperature, climate, and other ambient conditions.

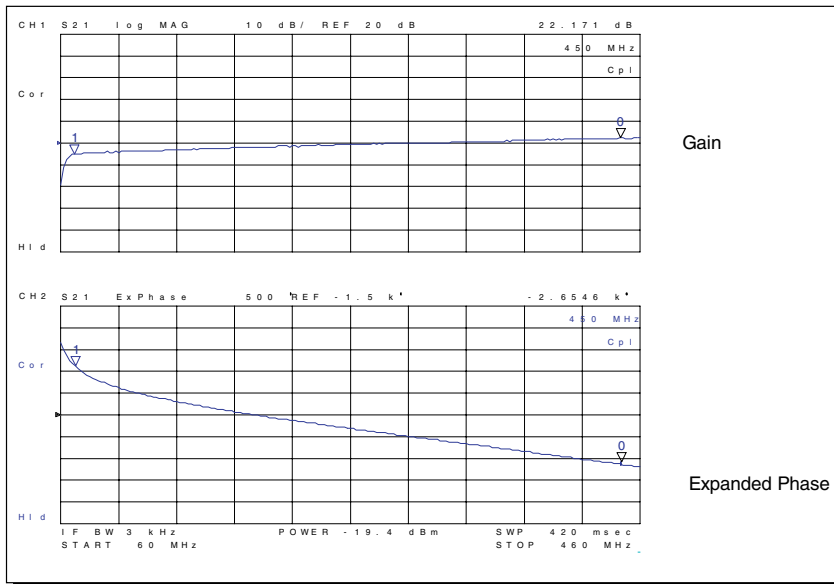

**Figure 3. Example of Amplitude-Expanded Phase Measurement Results**

- Amplitude
- Expanded Phase

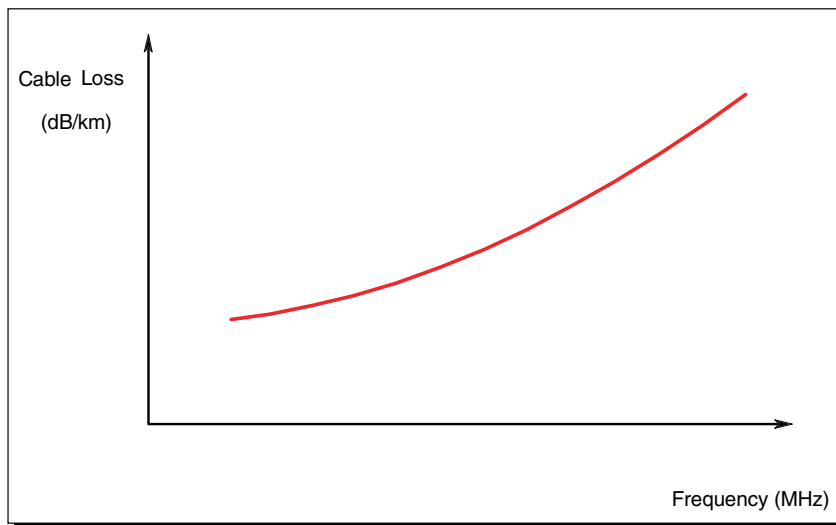

**Figure 4. Cable Loss vs Frequency Characteristic**

- Cable loss per unit length [dB/km]
- Frequency [MHz]

### **5-3-2. Efficient evaluation of gain control capability**

Because CATV amplifiers are designed to compensate for loss caused by cables or tapoffs, evaluation of gain control capability of amplifiers is extremely important. In general, gain control capability is evaluated by measuring and comparing the cable loss and the amplifier gain. To ensure efficient evaluation, it is possible to assume a transmission system composed of a cable and amplifier as shown in Figure 5, and to evaluate the gain achieved by the combined effect of cable and amplifier together.

Transmission system gain is given by Equation 2 as follows:

#### **Equation 2.**

Transmission system gain [dB] = CATV amplifier gain [dB]-Cable loss [dB]

That is, whether the system provides proper flatness over the entire frequency band determines the gain control performance of CATV amplifiers. With this method, frequency characteristic of cable loss is required. Though you can actually measure this characteristic, normally Equation 1 is used to obtain this characteristic. Note, however, that Equation 1 gives cable loss per km, which does not match the definition of cable loss used in Equation 2. Therefore, it is necessary to use one span as a standard unit of length as shown in Equation 3. One span is defined as the cable length at which the amplifier gain is equal to the cable loss at the maximum channel frequency (typically 450 MHz).

1 span = G (450)/Loss (450)

(1 span is typically several hundred meters.)

#### **Equation 3.**

Loss\_span(f) [dB] = Loss(f)/{Loss(450)/G(450)}

where,

G (450): Amplifier gain [dB]

At 450 MHz, the amplifier gain is equal to the cable loss per span. We hereafter refer to this cable loss per span, or Loss\_span (f), as cable loss. (See Figure 6.)

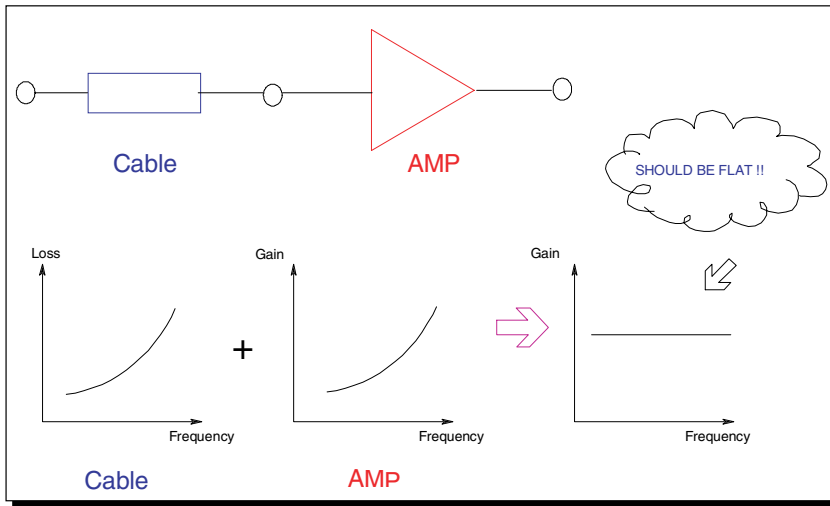

**Figure 5. Transmission System Composed of Cable and Amplifier**

- Cable
- Amplifier
- Loss
- Frequency
- Cable
- Gain
- Frequency
- Amplifier
- Gain
- Frequency

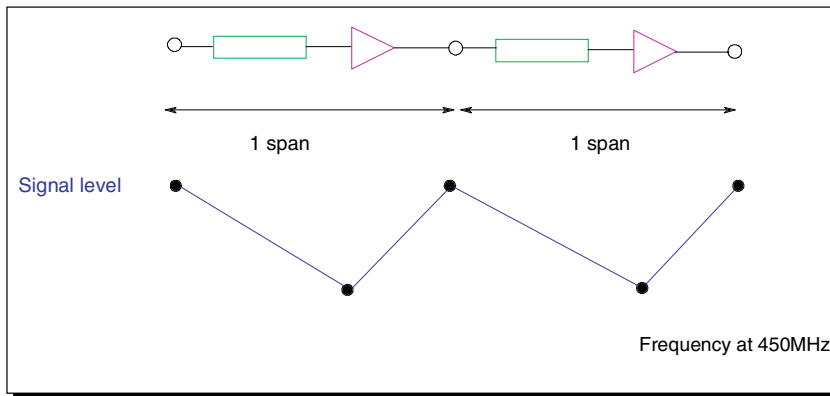

**Figure 6. Cable Loss per Span**

- 1 Span
- Signal Level
- Frequency: 450 MHz

From the preceding discussion, it is possible to assume that the relationship exists between cable loss and amplifier gain as shown in Figure 7. The transmission system should ideally achieve flatness of 0 dB, which is, however, not the case of actual systems due to the nonlinear characteristic of amplifier gain vs frequency. Modern CATV amplifiers are adjusted such that an impressive overall flatness of  $\pm 0.3$  dB to  $\pm 0.5$  dB is achieved over the channel frequency band.

As mentioned earlier, cable loss also varies depending on ambient conditions. Therefore, CATV amplifiers come with two types of gain control (GC) functions plus tilt control function to ensure proper cable loss compensation in accordance with changing ambient conditions. The GC functions can be classified into flat GC and twist GC functions. The flat GC function controls gain evenly over the entire frequency band while the twist GC function controls gain with different weights assigned to frequencies. The tilt function allows the gain frequency characteristic slope to be changed without changing the gain at the maximum channel frequency.

Cable loss is obtained by Equations 1 and 3 in consideration of the changes resulting from control made by these control functions. You will find an example of the relationship between cable loss and amplifier gain achieved by the above control. (In this case, the channel frequency range is assumed to be from 70 MHz to 450 MHz.)

Figure 8 shows the relationship between cable loss and amplifier gain when flat GC is set to 1 dB. This curve is obtained by adding 1 dB to cable loss and amplifier gain over the entire frequency range shown in Figure 7. The cable loss in this case is given by Equation 4 shown below.

**Equation 4.**

$$\text{Loss\_span}(f) \text{ [dB]} = \text{Loss}(f) / \{\text{Loss}(450) / G(450)\} + 1$$

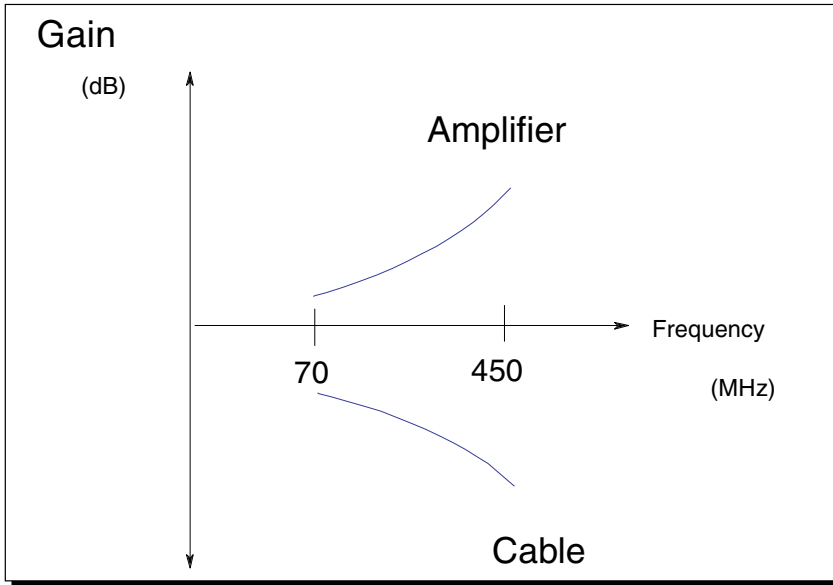

**Figure 7. Cable Loss and Amplifier Gain**

- Gain (dB)
- Amplifier
- Cable
- Frequency (MHz)

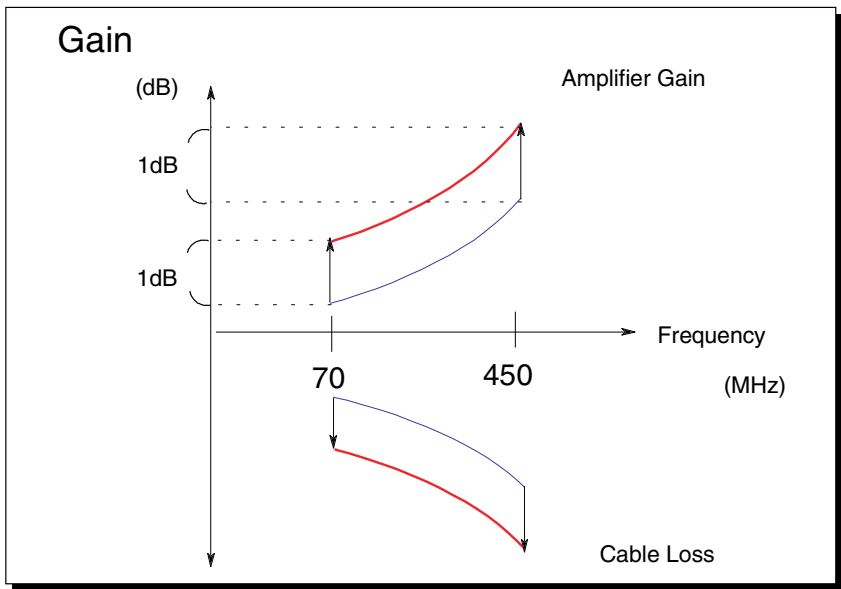

**Figure 8. Cable Loss and Amplifier Gain at Flat GC =1 dB**

- Gain (dB)
- Amplifier Gain
- Cable Loss
- Frequency (MHz)

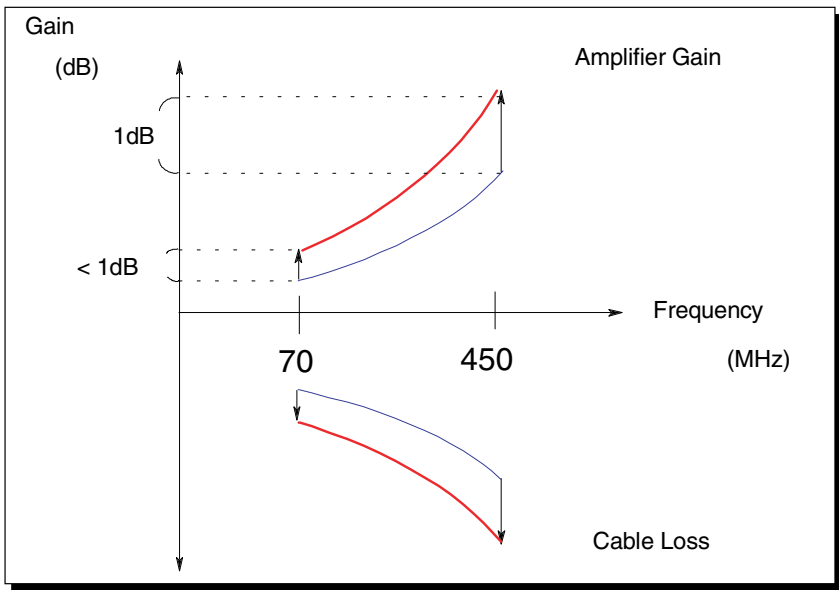

**Figure 9. Cable Loss and Amplifier Gain at Twist GC =1 dB**

- Gain (dB)
- Amplifier Gain
- Cable Loss
- Frequency (MHz)

Figure 9 shows the relationship between cable loss and amplifier gain when twist GC is set to 1 dB. The cable loss in this case is given by Equation 5 shown below.

**Equation 5.**

$$\text{Loss\_span}(f) \text{ [dB]} = \text{Loss}(f) / [\text{Loss}(450) / \{G(450) + 1\}]$$

Figure 10 shows the relationship between cable loss and amplifier gain when tilt function is set to 1 dB. The cable loss in this case is given by Equation 6 shown below.

**Equation 6.**

$$\text{Loss\_span}(f) \text{ [dB]} = \text{Loss}(f) / \{ \text{Loss}(450) / \{G(450)\} \} + (\text{Loss}(450) - \text{Loss}(f)) / (\text{Loss}(450) - \text{Loss}(70))$$

Note also, that depending on the type of amplifier to be tested, you can use another control method.

As shown above, you can evaluate gain control capability of CATV amplifiers through calculation of cable loss in accordance with each control parameter and through measurement of amplifier transmission characteristic after gain control.

**5-3-3. Example of evaluation**

The Agilent 4396B allows automatic measurement through its built-in IBASIC programming function. Also, with its fast measurement capability, built-in RAM disk, and limit test function, the 4396B allows real time Pass/Fail judgments of the unit under test for gain control capability. To test CATV amplifiers, follow the steps below.

- Calculate cable loss values for each control parameter and save them onto the RAM disk.
- Change the control parameter to measure the amplifier gain.
- Based on the measured gain, recall the corresponding cable loss value into the memory trace.
- Use the trace calculation function to display the flatness of the transmission line achieved by the cable and amplifier.
- Use the limit line function to determine whether the flatness is within the specified range.
- Repeat steps 2 through 5 to check the unit under test for all control parameters.

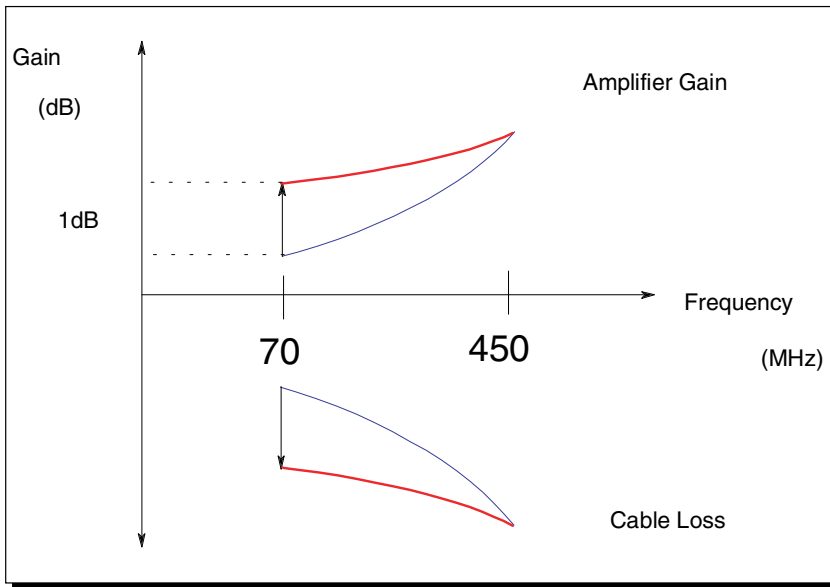

**Figure 10. Cable Loss and Amplifier Gain When Tilt =1 dB**

- Gain (dB)
- Amplifier Gain
- Cable Loss
- Frequency (MHz)

Figure 11 shows the flowchart of the Agilent 4396B IBASIC program.

Figure 12 shows an example of the CATV amplifier real time test results for gain control capability. This result shows that the device passed the test because its flatness remains within  $\pm 0.3$  dB for the entire frequency band.

#### **5-4. Reflection Coefficient (SWR-Return Loss) Measurement**

In addition to transmission characteristic, the 4396B allows highly accurate measurement of reflection characteristic, when coupled with the 85046B 75 $\Omega$  S-parameter Test Set. In operation, the 85046B separates the forward and reflected signals for measurement by the 4396B. Figure 13 shows a display example of SWR and return loss measurement results. Specifications typically require that the amplifier should have an SWR of less than 1.4 and a return loss higher than 14 dB. Therefore, we can see that this unit under test meets the specifications. Furthermore, the 4396B calculates and displays impedance of the test amplifier through its impedance conversion function.



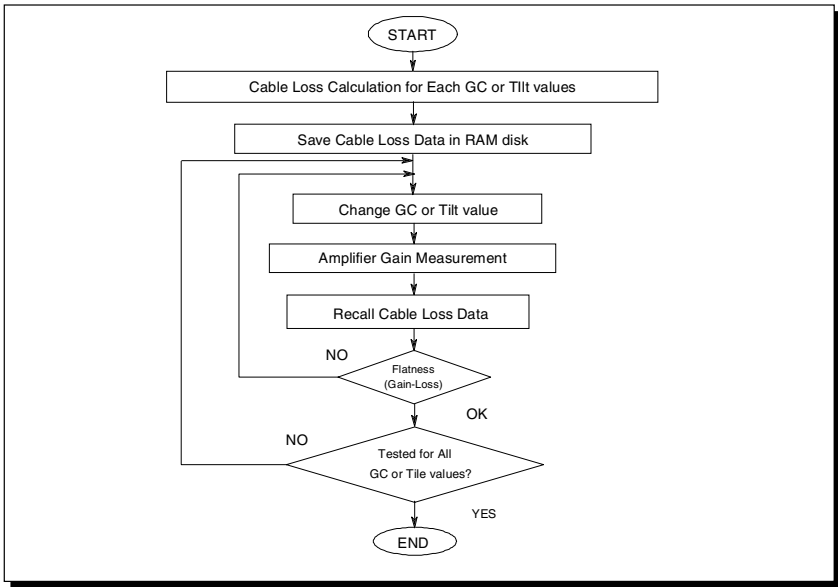

**Figure 11. Agilent 4396B IBASIC Program Flowchart**

- Calculating cable loss values for each control parameter
- Saving the values onto the RAM disk
- Changing CG control or tilt control value
- Measuring the amplifier gain
- Recalling the corresponding cable loss value
- Flatness (Gain-Loss)
- Tested for all CG or tilt control values

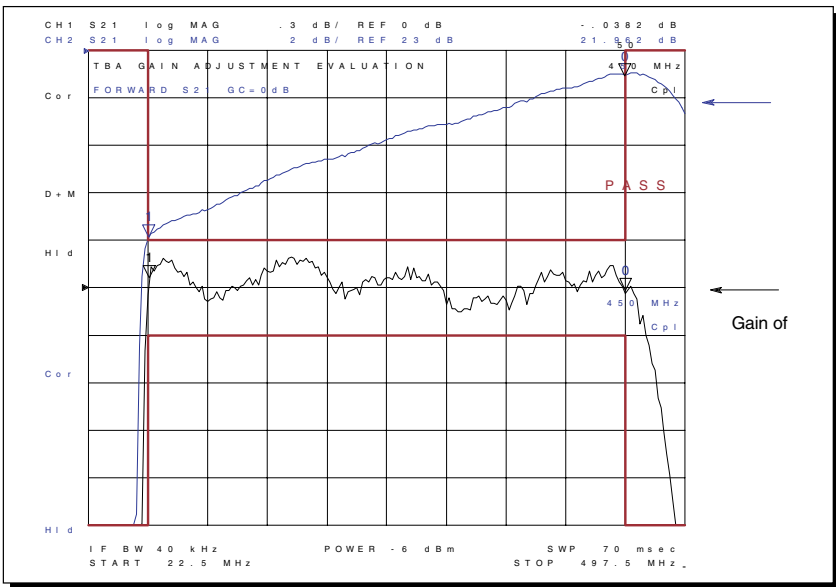

**Figure 12. Example of Real Time Pass/Fail Test Results for CATV Amplifier Gain Control Capability Using the Agilent 4396B**

- Amplifier Gain
- Entire System Gain

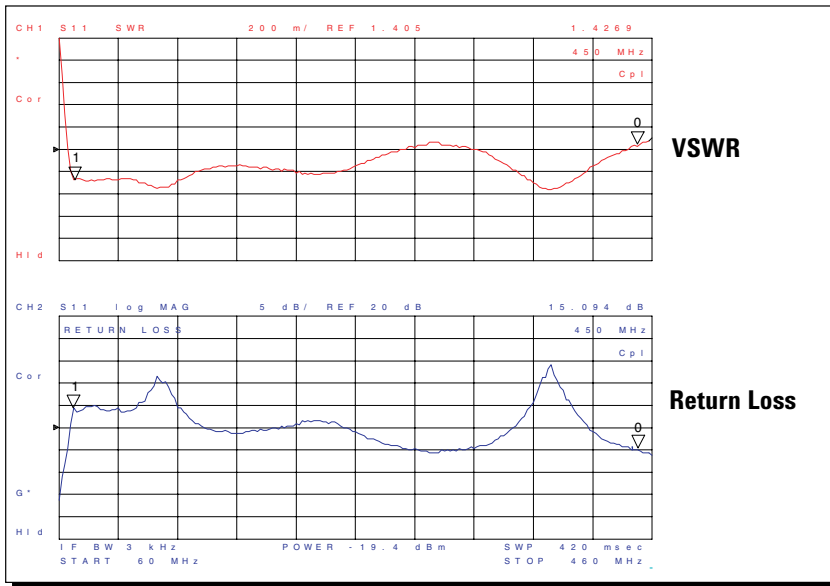

**Figure 13. CATV Amplifier Reflection Characteristic Measurement Results**

- SWR
- Return Loss

## 6. CATV Amplifier Spectrum Measurement

Generally, signal distortion is induced by nonlinear characteristic of a transmission device. For example, modulation distortion is caused by multiple signals passing through a device with a nonlinear transfer function. Since each CATV amplifier always amplifies a number of signals, it can cause a variety of intermodulation distortions if nonlinear characteristic resides in the device. Modulation distortion present on one channel can also affect some other channel frequency where a TV signal may be present. For example, if mutual modulation distortion appears on two signals; 131.25 MHz ( $f_1$ ) and 137.25 MHz ( $f_2$ ), then 125.25 MHz ( $2f_1-f_2$ ), the signal in the adjacent channel frequency band, may become distorted. In practice, every real amplifier involves some small amount of nonlinear performance, especially at the higher power levels. Therefore, distortion characteristic measurements are very important.

### 6-1. Spectrum Measurement Parameters and Definitions

#### *Composite Triple Beat (CTB)*

##### **EIAJ ET-2301 Standard**

Composite triple beat is defined as the ratio of each carrier output level to the maximum mean level of composite triple beat components appearing around that carrier output when all channel carriers are fed to the unit under test without modulation.

**NCTA Standard**

Composite triple beat is defined as the modulation beat of the target channel signal caused by triple beat resulting from the nonlinear characteristic of the unit under test. Composite triple beat is expressed as the ratio of the target channel signal level to the maximum mean level of beat components dispersed around the carrier of that target channel.

***Composite Second Order Beat (CSO)*****EIAJ ET-2301 Standard**

Composite second order beat is defined as the ratio of each carrier output level to the maximum mean level of composite second order beat components appearing within the channel having a 6 MHz-wide band when all channel carriers are fed to the unit under test without modulation.

**NCTA Standard**

Composite second order beat is defined as the modulation beat of the target channel signal caused by second order beat resulting from the nonlinear characteristic of the unit under test. Composite second order beat is expressed as the ratio of the target channel signal level to the maximum mean level of beat components dispersed around 0.75 MHz and 1.25 MHz above and below the carrier of that channel.

***Cross Modulation Distortion*****EIAJ ET-2301 Standard**

Cross modulation distortion is defined as amplitude-modulated carrier components of undesired channels appearing in the target channel due to nonlinear distortion. Cross modulation distortion is expressed as the ratio of the level of amplitude-modulated carrier components of the target channel at 100% modulation to the level of carrier components of undesired channels.

**NCTA Standard**

Cross modulation is defined as the distortion that causes modulated carrier components of undesired channels to amplitude-modulate the target channel carrier due to the nonlinear characteristic of the unit under test. Cross modulation distortion is expressed as the ratio of the target channel carrier level to the level of modulated components of the carrier of the target channel resulting from modulated signals of undesired channels.

***Inter-modulation Distortion (IMD)*****EIAJ ET-2301 Standard**

Inter-modulation distortion is defined as the ratio of the level of distortion components resulting from the nonlinear characteristic of the unit under test, whose frequencies are equal to the sums and differences of the original signals, to the level of the carrier subjected to interference.

## **Hum Modulation**

### **EIAJ ET-2301 Standard**

Hum modulation is defined as the ratio of the level of signal components, appearing in the carrier output by the unit under test when such components are modulated by the commercial power frequency, referenced to the carrier level.

### **NCTA Standard**

Modulation distortion at the power source frequency (hum modulation) is defined as the amplitude modulation distortion of channel signals resulting from power source signal components modulating the target channel signals. Modulation distortion at the power source frequency is expressed in percentage or dB as the ratio of the peak-to-peak value of modulated signal components to the maximum target channel signal level.

## **6-2. Agilent 4396B Features in CATV Amplifier Spectrum Measurement**

CATV amplifiers are designed to minimize distortion and to ensure transmission of high quality TV signals. Thus, the test instrument must be able to perform measurement under conditions of low noise and narrow resolution bandwidth.

### **Low Noise Level**

The 4396B offers a noise level of -147 dBm/Hz at 1 GHz for distortion measurement, an extremely low noise level that has not been readily available with conventional spectrum analyzers. Further, the 4396B features digital filters with a 3-to-1 shape factor, sufficiently steep for clear display of low-level signals as separate spectrum components.

### **Fast Measurement at Narrow Bandwidth**

The 4396B features a stepped Fast Fourier Transform (FFT) technique for fast and narrow band spectrum measurement, ideal for low-level distortion measurement. For example, with a 10 Hz RBW and 2 kHz span, the 4396B requires less than one second for sweep time while conventional sweeping spectrum analyzers take about fifty seconds.

### **Other Features**

The 4396B offers simultaneous display of two spectra measured with different parameters on a single screen, allowing you to display carrier and distortion spectra at the same time. In this display, the marker functions help you compare numerical values in both spectra.

## **6-3. Spectrum Measurement Setup**

### **6-3-1. Reference level calibration**

Because the input/output impedances of CATV amplifiers are 75 $\Omega$ , spectrum measurement must be conducted using a test instrument with 75 $\Omega$  input impedance to ensure proper measurement. The 4396B, when coupled with option 1D7, allows easy reference level calibration for 75 $\Omega$  input impedance, as shown in Figure 14. One advantage with this option is that absolute power levels are referenced to a 75 $\Omega$  system.

### 6-3-2. Measurement system configuration

Figure 15 shows a measurement system configuration for CTB, CSO, and cross modulation distortion. Measurement of these parameters requires a multi-channel signal generator because multiple signals within the entire channel frequency range need to be fed to the amplifier at the same time. Variable attenuators are used to ensure that the amplifier input and output power levels remain at the standard operation level.

A band-pass filter is recommended to prevent saturation of input to the 4396B and to ensure that only signals near the target channel frequency are measured. In general, several types of variable band-pass filters are used to cover a wide frequency range of 10 MHz to 452 MHz. The 11852B (option C04) 50Ω/75Ω minimum loss pad is used to ensure proper impedance matching between 75Ω input and output impedance of amplifier and the 50Ω input impedance of the 4396B.

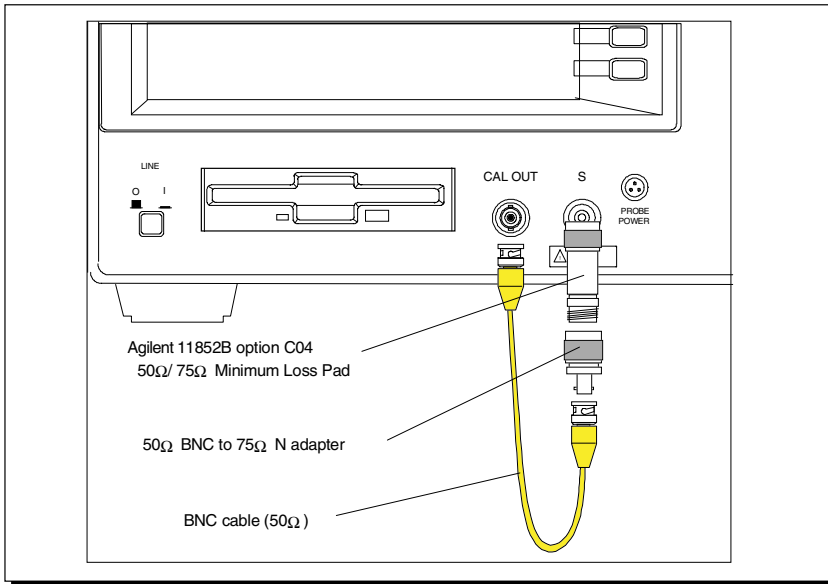

**Figure 14. Reference Level Calibration of the Agilent 4396B for Measurement of Amplifier with 75Ω Impedance**

- 11852B Option C04 50Ω/75Ω Minimum Loss Pad
- 50Ω-75Ω BNC Adapter
- BNC Cable (50Ω)

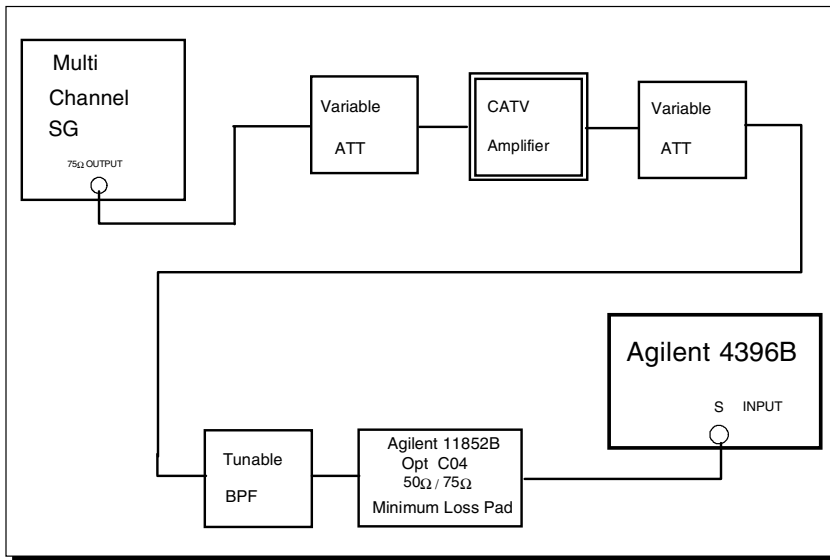

**Figure 15. Measurement System Configuration for CTB, CSO, and Cross Modulation Distortion**

- Multi-Channel Signal Generator
- 75Ω OUTPUT
- Variable Attenuator
- CATV Amplifier
- Variable Attenuator
- Variable Band-pass Filter
- 11852B Option C04 50Ω/75Ω Minimum Loss Pad

#### 6-4. Multi-channel Signal Measurement

Figure 16 shows the carrier levels measured by the Agilent 4396B of all channel frequencies from a multi-channel signal generator. As you can see, 59 channel carriers ranging from 69.25 MHz to 451.25 MHz are fed at mostly 6 MHz intervals. CTB, CSO, and cross modulation distortion are measured based on these carriers.

#### 6-5. Composite Triple Beat (CTB )

##### 6-5-1. Example of measurement conditions

*Center frequency:* 199.25 MHz

*Sweep span:* 500 kHz

*Resolution bandwidth (RBW):* 30 kHz

*Video bandwidth (VBW):* 100 Hz

The 4396B resolution bandwidth is set relatively wide at 30 kHz to provide the maximum mean level of distortion components found around the target channel frequency. This prevents distortions from being measured as individual spectra.

### 6-5-2. Measurement procedure

Follow the steps below to measure CTB.

- Adjust each channel output of the multi-channel signal generator as well as the attenuator output until the output of the unit under test reaches the standard operation level.
- Measure the level of the target channel carrier.
- Save measurement data in the memory trace.
- Shut off the target channel carrier output of the signal generator.
- Reduce the attenuation by 10 dB to ensure proper measurement of low-level distortions with 30 kHz RBW.
- Because the target distortions are third order distortions, their level changes three times as much as the carrier level. Therefore, set the data offset at 30 dB (10 dB x 3). At this time, check that the distortion actually changes three times as much as the carrier level.
- Measure the distortion signal level.
- Use marker functions to compare the carrier and distortion levels.

### 6-5-3. Example of measurement results

Figure 17 shows an example of CTB measurement results. Using the marker list and delta marker functions, you can easily find that the CTB is -97 dBc. As you can see, instead of forming a single spectrum, CTBs are scattered over the range between 50 kHz below and above the target channel frequency because of small fluctuations of each carrier signal.

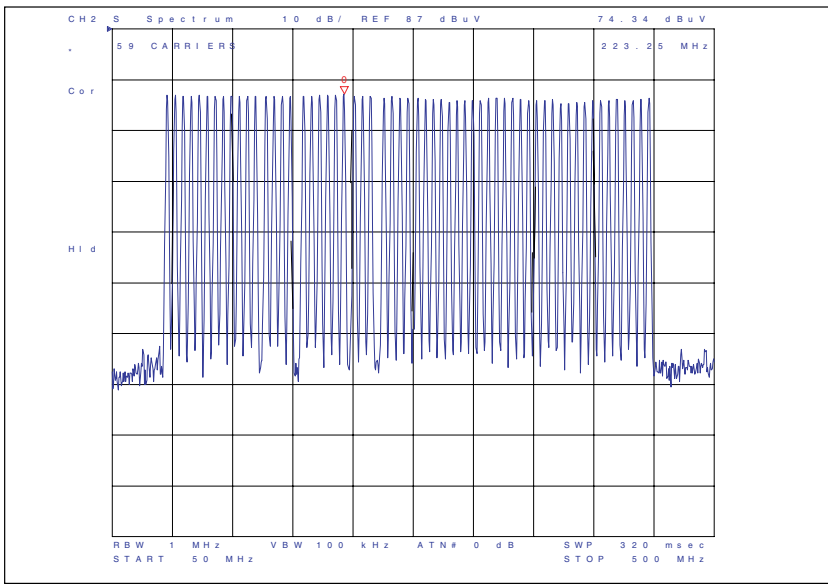
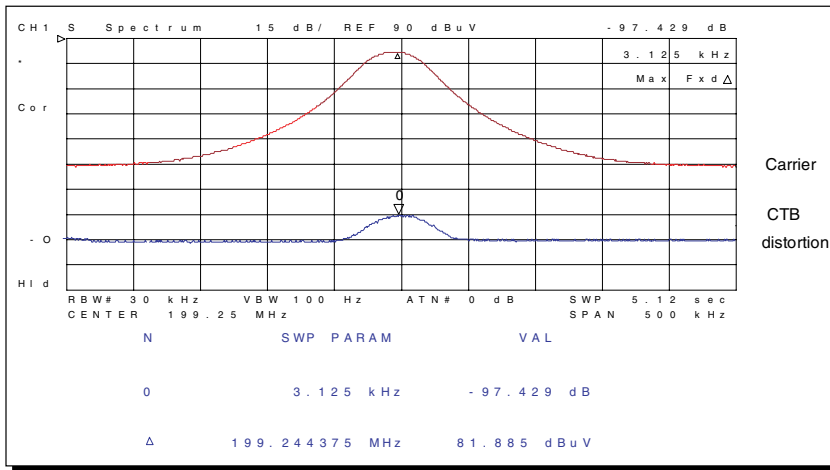

Figure 16. Carrier Output from Multi-Channel Signal Generator



**Figure 17. CTB Measurement Results Using the Agilent 4396B**

- Carrier
- Distortion

## 6-6. Composite Second Order Beat (CSO)

### 6-6-1. Example of measurement conditions

Center frequency for carrier measurement (channel 1): 103.25 MHz

(carrier frequency for target channel)

Center frequency for distortion measurement (channel 2): 102 MHz or 104.5 MHz

Sweep span: 500 kHz

Resolution bandwidth (RBW): 30 kHz

Video bandwidth (VBW): 100 Hz

### 6-6-2. Measurement procedure

Follow the steps below to measure CSO.

- Adjust each channel output of the multi-channel signal generator as well as the attenuator output until output of the unit under test reaches the standard operation level.
- Measure the carrier level through channel 1 of the 4396B.
- Switch the 4396B over to channel 2.
- Reduce the attenuation by 10 dB to ensure proper measurement of low-level distortions.
- Set the center frequency at 1.25 MHz away from the carrier frequency.
- Because the target distortions are second order distortions, their level changes twice as much as the carrier level. Therefore, set the data offset at 20 dB (10 dB x 2). At this time, check that the distortion actually changes twice as much as the carrier level.
- Measure the distortion signal level.
- Use marker functions to compare the carrier and distortion levels.



### **6-6-3. Example of measurement results**

Figure 18 shows an example of CSO measurement results. The two marker readings show that the CSO is approximately -89 ( $83 - (-5.8) = 88.8$ ) dBc. As you can see, instead of forming a single spectrum, CSO distortions are scattered over the range between 50 kHz below and above the target channel frequency because of small fluctuations of each carrier signal.

## **6-7. Cross Modulation Distortion**

### **6-7- 1. Example of measurement conditions**

*Center frequency:* 199.25 MHz

*Sweep span:* 50 kHz

*Resolution bandwidth (RBW):* 1 kHz

*Video bandwidth (VBW):* 300 Hz or 100 Hz

*Averaging factor:* 50 (during distortion measurement)

Multi-channel signal generator setup:

Set the generator for 100% amplitude modulation by 15.75 kHz square wave.

### **6-7- 2. Measurement procedure**

Because the measurement procedure for cross modulation distortion is defined differently in EIAJ ET-2301 than in NCTA, both procedures are given below.

#### **EIAJ ET-2301 Standard**

- Adjust each channel output of the multi-channel signal generator as well as the attenuator output until output of the unit under test reaches the standard operation level.
- Apply amplitude-modulation to all carriers and measure the modulated carrier component of the target channel.
- Stop the amplitude modulation of the target channel carrier. Reduce the attenuation by 10 dB to ensure proper measurement of low-level distortions.
- Because the target distortions are third order distortions, their level changes 3 times as much as the carrier level. Therefore, set the data offset at 30 dB (10 dB x 3). At this time, check that the distortion actually changes three times as much as the carrier level.
- Measure the distortion signal level.
- Use the delta marker and marker list functions to compare the carrier and distortion levels.

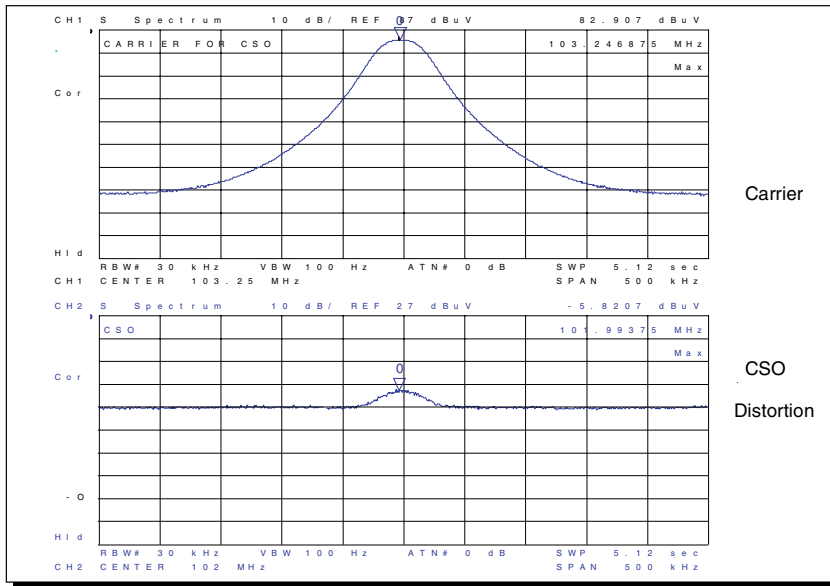

**Figure 18. CSO Measurement Results Using the Agilent 4396B**

- Carrier
- Distortion

**NCTA Standard**

- Adjust each channel output of the multi-channel signal generator as well as the attenuator output until output of the unit under test reaches the standard operation level.
- Amplitude-modulate all carriers except the target channel frequency carrier.
- Reduce the attenuation by 10 dB to ensure proper measurement of low-level distortions. At this time, check that the distortion actually changes three times as much as the carrier level.
- Measure the target channel carrier level and distortion signal level.
- Use the delta marker and marker list functions to compare both levels. (At this time, the third order distortion level changes by a factor of three. The actual level of the distortion is smaller by 20 dB (10 dB x (3-1)). Therefore, subtract 20 dB from the measured level to obtain the actual level.)

Strictly speaking, measurement results obtained through these procedures include not only the amplitude-modulated components but the phase-modulated components resulting from the phase relationship between carrier and modulated signals within the side bands. Therefore, the level of distortions measured may be greater than that of amplitude modulation distortion alone. However, the impact of phase-modulated components does not pose problems to measurement results because the level of such components can be considered smaller than that of amplitude-modulated components, and also because amplifiers can be evaluated based on their worst performance.

**6-7- 3. Example of measurement results**

Figures 19 and 20 show an example of CSO measurement results per EIAJ ET-2301 and NCTA, respectively. Using the marker list and delta marker functions, you can easily find that the cross modulation distortion is -92 dBc.

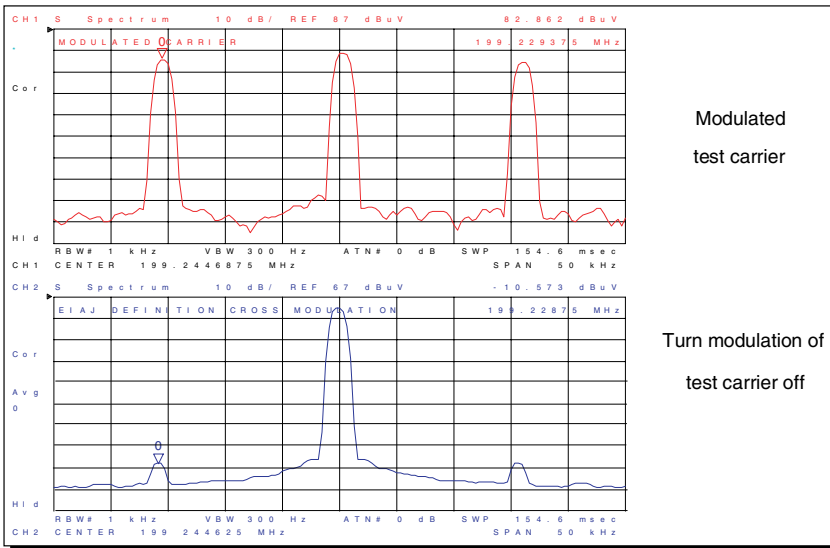

**Figure 19. Example of Cross Modulation Distortion Measurement Results Using the Agilent 4396B (per EIAJ ET-2301 Standard)**

- Amplitude-Modulated Carrier
- Target Channel Carrier without Amplitude Modulation

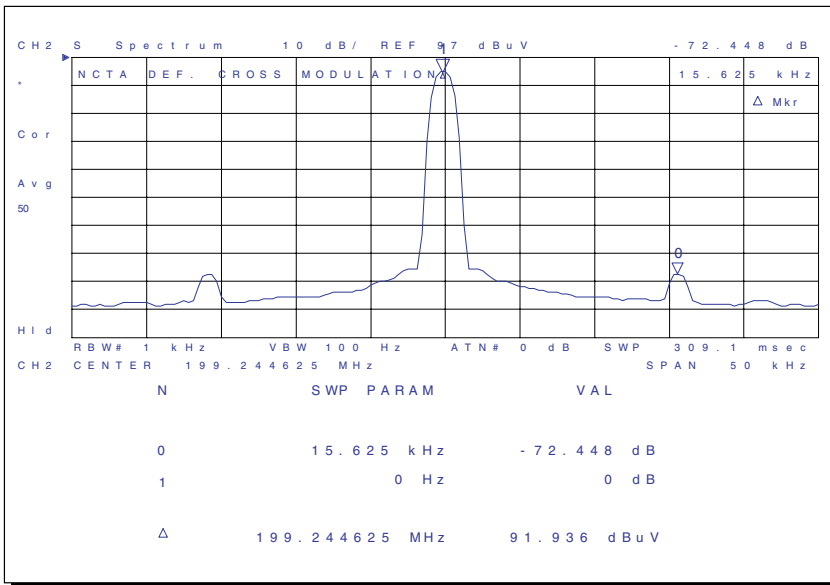

**Figure 20. Example of Cross Modulation Distortion Measurement Results Using the Agilent 4396B (per NCTA Standard)**

## 6-8. Inter-modulation Distortion (IMD )

### 6-8-1. Measurement system configuration

Figure 21 shows a measurement system configuration for inter-modulation distortion caused by two signals modulating each other. The EIAJ ET-2301 standard requires that the level of the target carrier as well as inter-modulation distortion appearing around the target carrier frequency be measured when this carrier is combined with the carrier of another channel. To do this, two waves generated by two separate generators are combined by a mixer. The minimum loss pad and band-pass filter are used to serve the same purpose as for CTB measurement. The low-pass filter is used to cut off higher harmonics.

### 6-8-2. Example of measurement conditions

This example shows how to measure the level of distortion components appearing around the frequency resulting from the sum of two carrier frequencies as well as the level of channel carriers near that frequency.

*Signal generator settings:* 103.25 MHz and 109.25 MHz

*Carrier frequency during measurement (signal generator #1 output):*

211.25 MHz

- Channel 1 (carrier level measurement)  
*Center frequency:* 211.25 MHz  
*Sweep span:* 1 MHz  
*Resolution bandwidth (RBW):* 3 kHz  
*Video bandwidth (VBW):* 3 kHz
- Channel 2 (distortion level measurement)  
*Center frequency:* 212.5 MHz  
*Sweep span:* 2 kHz  
*Resolution bandwidth (RBW):* 3 Hz  
*Video bandwidth (VBW):* 3 Hz

A narrow RBW must be used as shown above due to low inter-modulation distortion level.

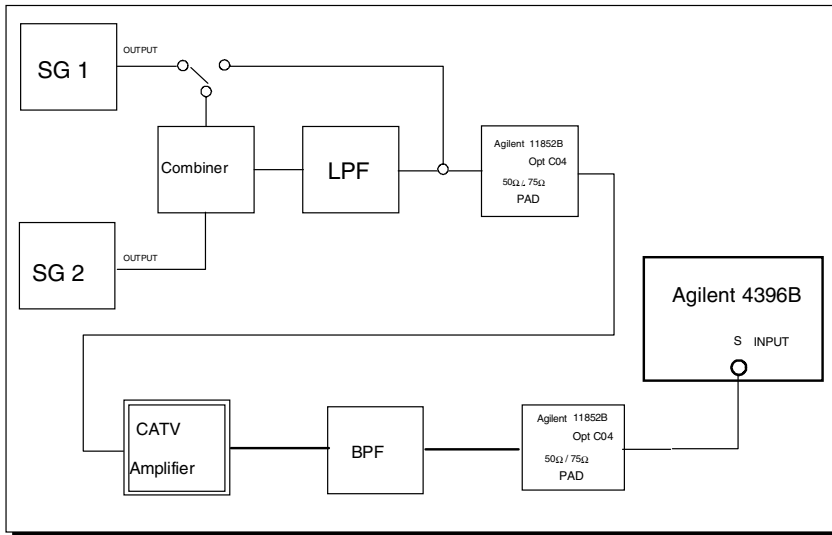

**Figure 21. Example of Measurement System Configuration for Inter-Modulation Distortion**

- Signal Generator 1 (e.g. Agilent 8662A)
- Signal Generator 2 (e.g. Agilent 8662A)
- Mixer
- Low-pass Filter
- Agilent 11852B 50Ω/75Ω Minimum Loss Pad
- CATV Amplifier
- Band-pass Filter
- Agilent 11852B 50Ω/75Ω Minimum Loss Pad

### **6-8-3. Measurement procedure**

Follow the steps below to measure IMD.

- In the beginning, use the network analyzer function of 4396B to measure the insertion loss of the band-pass filter to be used. Then, set the offset function so that the insertion loss is compensated for.
- Adjust each carrier output level of two signal generators until the output of the unit under test reaches the standard operation level.
- Apply the output of Signal Generator 1 directly to the minimum loss pad.
- Measure the carrier level of the measurement channel through channel 1 of the 4396B.
- Direct the output of Signal Generator 1 to the mixer.
- Switch the 4396B over to channel 2. Measure the distortion signal level.
- Use marker functions to compare the carrier and distortion levels.

### **6-8-4. Example of measurement results**

Figure 22 shows an example of inter-modulation distortion measurement results. Using marker functions, you find that the inter-modulation distortion is 97 (88- (-9)) dBc.

## 6-9. Hum Modulation

### 6-9-1. Measurement system configuration

Figure 23 shows a measurement system configuration for hum modulation. The minimum loss pad and band-pass filter are used for the same purpose as for other measurements.

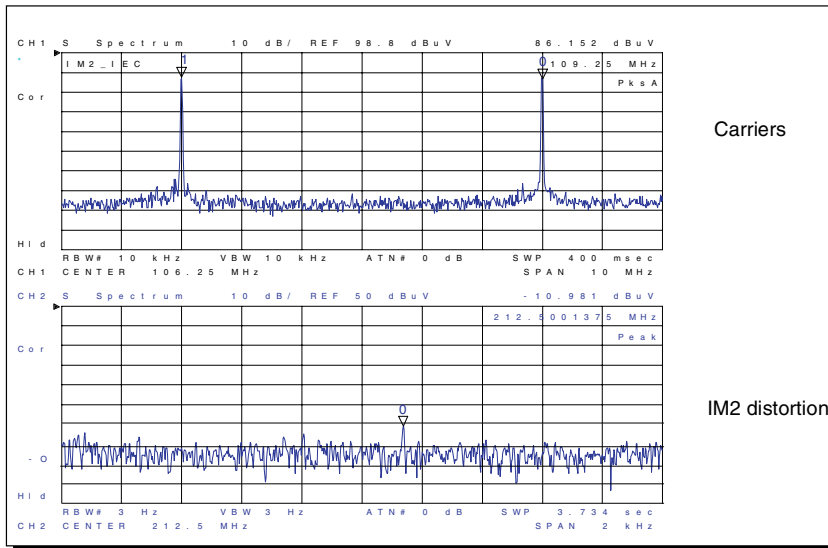

**Figure 22. Example of Inter-Modulation Distortion Measurement Results Using the Agilent 4396B**

- Carrier
- Distortion

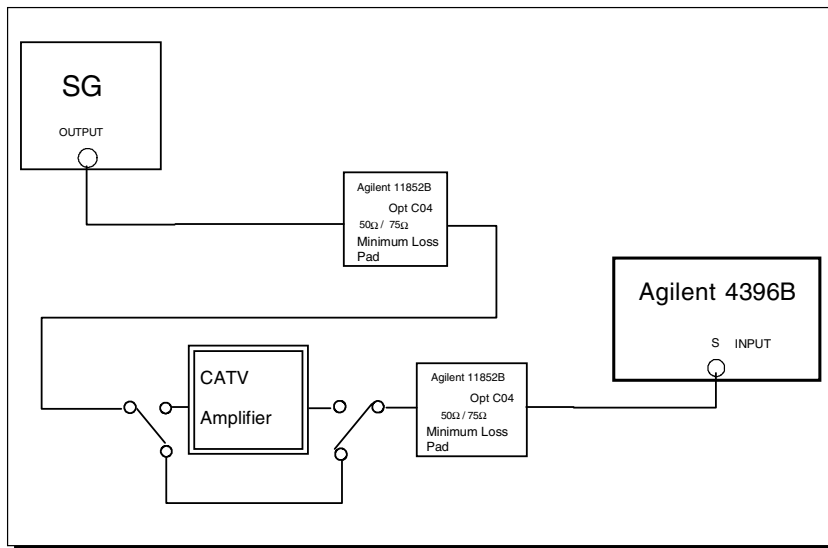

**Figure 23. Example of Measurement System Configuration for Hum Modulation**

- Signal Generator (e.g. Agilent 8662A)
- Agilent 11852B 50Ω/75Ω Minimum Loss Pad
- CATV Amplifier
- Agilent 11852B 50Ω/75Ω Minimum Loss Pad

### **6-9-2. Example of measurement conditions**

*Target carrier frequency:* 451.25 MHz

*Center frequency:* 451.25 MHz

*Sweep span:* 150 Hz

*Resolution bandwidth (RBW):* 1 Hz

*Video bandwidth (VBW):* 1 Hz

Side band phase noise and hum modulation present in the signal generator must be lower than those in the unit under test. Many Agilent signal generators provide such low-noise signal performance, and are specified for such applications. Also, an extremely narrow RBW, or 1 Hz, must be used to ensure proper measurement of modulated components whose level is substantially small.

### **6-9-3. Measurement procedure**

Follow the steps below to measure hum modulation.

- Adjust the output of signal generators until it reaches the input level of the unit under test.
- Measure the level of the carrier and the hum modulated components without allowing them to pass through the unit under test.
- Use the offset function to apply offset, equal to the amplifier gain at 451.25 MHz, to measurement data.
- Save the measurement data in the memory trace.
- Cancel the offset function.
- Connect the signal generator to the unit under test to measure the level of the carrier and the hum modulated components.
- Check that the level of amplitude modulated components caused by the power source is higher than that saved in the memory trace.
- Use the marker list and delta marker functions to compare the carrier and hum modulated component levels.

### **6-9-4. Example of measurement results**

Figure 24 shows an example of hum modulation measurement results in the case that the power source frequency is 60 Hz. Note that the memory trace is not shown. Using the marker list and delta marker functions, you can easily find that the hum modulation distortion is approximately -84 dBc. The 4396B takes only approximately five seconds for sweep time even when RBW is as low as 1 Hz.

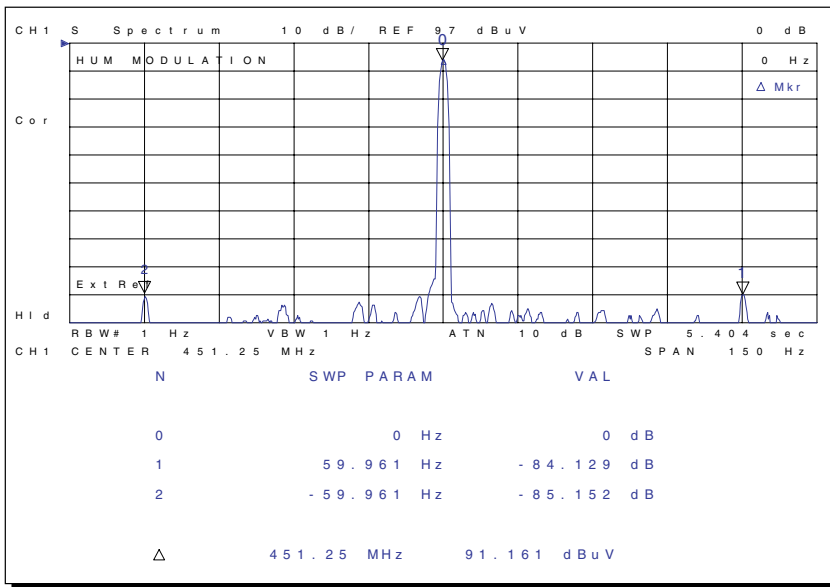

Figure 24. Example of Hum Modulation Measurement Results

## 7. Summary of Agilent 4396B Features for CATV Amplifier Measurement

The following lists the features available with the 4396B for CATV amplifier measurement.

### Network Measurement

- Accurate amplitude and phase measurement
- Fast sweep for real time gain control capability evaluation
- Pass/Fail judgments through the limit line function
- Automatic measurement and external equipment control capability through the IBASIC (Instrument BASIC) function (available as standard)
- Impedance-matched measurement for amplifiers with 75Ω input and output impedance

### Spectrum Measurement

- Simultaneous display of two measurement results through two-channel measurement
- Low noise level for small distortion measurement
- Fast measurement with narrow RBW, as in inter-modulation distortion and hum modulation
- Impedance-matched measurement for amplifiers with 75Ω input/output impedance

### Other Useful Features

- Easy comparison of measurement data through the memory trace and offset functions
- Powerful marker-aided analysis functions (peak search and marker list functions)
- Two types of data storage functions



## **Conclusion**

Higher quality signal performance is increasingly required for CATV amplifiers. Thus, their characteristics should be evaluated in both network and spectrum measurements with sufficiently high accuracy. With its superior features and excellent performance, the 4396B RF Network/Spectrum/Impedance Analyzer will deliver an ideal and cost-effective solution, allowing both network and spectrum measurements of extremely high accuracy in one instrument, thus contributing to investment cost reduction in the installation and operation of modern CATV systems.

## **References**

### **Measurement standard:**

- EIAJ ET-2301 CATV System Equipment Measurement Procedures
- IEC Pub 728-1 Cabled Distribution Systems
- NCTA Recommended Practices for Measurements on Cable Television Systems (Second edition)

This note has been made available through the cooperation of Furukawa Electric Industries Co., Ltd.

By internet, phone, or fax, get assistance with all your test and measurement needs.

**Online Assistance**

[www.agilent.com/find/assist](http://www.agilent.com/find/assist)

**Phone or Fax**

United States:

(tel) 1 800 452 4844

Canada:

(tel) 1 877 894 4414

(fax) (905) 206 4120

Europe:

(tel) (31 20) 547 2323

(fax) (31 20) 547 2390

Japan:

(tel) (81) 426 56 7832

(fax) (81) 426 56 7840

Latin America:

(tel) (305) 269 7500

(fax) (305) 269 7599

Australia:

(tel) 1 800 629 485

(fax) (61 3) 9210 5947

New Zealand:

(tel) 0 800 738 378

(fax) (64 4) 495 8950

Asia Pacific:

(tel) (852) 3197 7777

(fax) (852) 2506 9284

Product specifications and descriptions in this document subject to change without notice.

Copyright © 1997, 2000 Agilent Technologies

Printed in U.S.A. 9/00

5965-9434E



**Agilent Technologies**

Innovating the HP Way